

FENIX 300 SERIES

Rockwell | Brinell | Universal Hardness Testers

SEMI-AUTOMATIC



FENIX 300RS

Sense, Simplicity, affordable top technology...

The FENIX 300RS combines today's load application technology with a top class German made depth measuring system. Rockwell, Superficial Rockwell & Brinell scales are part of the machine's capabilities. High accurate test results and fast operation make the FENIX 300 series the best work horse in its class on the market today. The entry model 300 RS provides a smart User Interface, easy to learn and with internal and external data storage options.

ROCKWELL & BRINELL FORCE RANGE:

| | | | | |
|------|------|-------------|--------|--------|
| 1kgf | 3kgf | FENIX 300RS | 150kgf | 250kgf |
|------|------|-------------|--------|--------|

HARDNESS SCALES



ROCKWELL 3kgf – 150kgf



BRINELL 1kgf - 250kgf
(Optional)

FENIX 300RS-IMP

Workflow process visualisation, advanced connectivity...

The IMP version of the FENIX 300RS combines the excellent force application and measuring system with an advanced machine controller running on Windows 10. Make connection to your network by WIFI or LAN, connect to a printer, a Quality system or MS application; the IMPRESSIONS™ LT system offers great flexibility.

ROCKWELL & BRINELL FORCE RANGE:

| | | | | |
|------|------|-----------------|--------|--------|
| 1kgf | 3kgf | FENIX 300RS-IMP | 150kgf | 250kgf |
|------|------|-----------------|--------|--------|

HARDNESS SCALES



ROCKWELL 3kgf – 150kgf



BRINELL 1kgf - 250kgf
(Optional)



HIGHLIGHTS

- 1 Rockwell, Superficial Rockwell & Brinell (opt.)
- 2 Load Cell, closed loop force control system
- 3 Direct depth measurement on indenter shaft
- 4 Depth reading tolerance 0.05µm
- 5 Clamping nose to fix workpieces & indenter protection
- 6 Integrated LED Sample illumination
- 7 I-TOUCH™ software system, advanced tester control
- 8 Industrial 6.5" touchscreen
- 9 Optional Brinell measurement module
- 10 USB connectivity
- 11 Massive full steel C-frame for best GR & R results
- 12 Replaceable ABS bottom cover avoids body damage



HIGHLIGHTS

- 1 Rockwell, Superficial Rockwell & Brinell (opt.)
- 2 Load Cell, closed loop force control system
- 3 Direct depth measurement on indenter shaft
- 4 Depth reading tolerance 0.05µm
- 5 Clamping nose to fix workpieces & indenter protection
- 6 Integrated LED Sample illumination
- 7 **IMPRESSIONS™ LT Software, workflow control**
- 8 **Integrated Industrial PC, Windows 10 Licensed**
- 9 Industrial 6.5" touchscreen
- 10 **Multi USB, LAN, WLAN, (Bluetooth opt.) connectivity**
- 11 **Optional integrated software for Brinell and BIOS – Brinell Indent Optical Scanner**
- 12 Massive full steel C-frame for best GR & R results
- 13 Replaceable ABS bottom cover avoids body damage

FENIX 300U

Not sure of your future needs..?

In addition to Rockwell and Superficial Rockwell, the FENIX 300U has the ability to perform Vickers, Knoop and Brinell scales. A fit for purpose machine for workshops usually measuring Rockwell scales and occasionally Vickers, Knoop or Brinell. Excellent choice for education institutes such as technical schools, universities and versatile general workshops. The electronic microscope with exchangeable lenses and ringlight for the measurement of shallow Brinell indents is easy to use and provides crisp images of the indent.

UNIVERSAL FORCE RANGE:

| | | | | |
|------|------|------------|--------|--------|
| 1kgf | 3kgf | FENIX 300U | 150kgf | 250kgf |
|------|------|------------|--------|--------|

HARDNESS SCALES

| | | |
|---|-----------------|---------------|
|  | ROCKWELL | 3kgf – 150kgf |
|  | BRINELL | 1kgf - 250kgf |
|  | VICKERS | 1kgf – 120kgf |
|  | KNOOP | 1kgf – 5kgf |

HIGHLIGHTS

- 1 Rockwell, Superficial Rockwell, Vickers, Knoop & Brinell
- 2 Load Cell, closed loop force control system
- 3 Direct depth measurement on indenter shaft
- 4 Depth reading tolerance 0.05µm
- 5 Clamping nose to fix workpieces & indenter protection
- 6 Integrated LED Sample illumination
- 7 I-TOUCH™ software system, advanced tester control
- 8 Industrial 6.5" touchscreen
- 9 **Electronic eyepiece, microscope system and integrated ring light for Brinell measurements (optional)**
- 10 **Sliding table for Brinell and Vickers measurements**
- 11 USB connectivity
- 12 Massive full steel C-frame for best GR & R results
- 13 Replaceable ABS bottom cover avoids body damage



FENIX 300XL



Reaching out to the stars...

The XL version of the FENIX range combines all the specifications of the standard 300RS model with a much taller work space. The test height available on this model can be used for both Rockwell scales as well as for the Brinell scales.

ROCKWELL & BRINELL FORCE RANGE:

| | | | | |
|------|------|-------------|--------|--------|
| 1kgf | 3kgf | FENIX 300XL | 150kgf | 250kgf |
|------|------|-------------|--------|--------|

HARDNESS SCALES

| | | |
|--|------------------------------|---------------|
|  | ROCKWELL | 3kgf – 150kgf |
|  | BRINELL (Optional) | 1kgf - 250kgf |

HIGHLIGHTS

- 1 Rockwell, Superficial Rockwell & Brinell (opt.)
- 2 **Extra large working height 470mm**
- 3 Load Cell, closed loop force control system
- 4 Direct depth measurement on indenter shaft
- 5 Depth reading tolerance 0.05µm
- 6 Clamping nose to fix workpieces & indenter protection
- 7 Integrated LED Sample illumination
- 8 I-TOUCH™ software system, advanced tester control
- 9 Industrial 6.5" touchscreen
- 10 USB connectivity
- 11 Massive full steel C-frame for best GR & R results
- 12 Replaceable ABS bottom cover avoids body damage



FENIX RANGE

Phoenix, arising again and again, our 3rd generation of the most popular range of Rockwell hardness testing machines is now offering high-end testing technology, an optional advanced integrated Windows 10 system controller, a universal or extra tall model; at very affordable pricing.

Constructed around a solid steel frame, the FENIX 300 series includes a best in its class depth measuring system providing a stable maximum tolerance of less than 0.05µm. The combination of these 2 key elements and a Load Cell, Closed Loop force feedback system provides a workhorse, a hardness tester for use in the more demanding workshop or QC department.

Expanding the capabilities of the FENIX 300 line is as easy as the addition of Optical hardness testing of Vickers, Knoop and Brinell. Manual Microscope, Brinell Optical indent scanning system (BIOS) or for the FENIX 300U an integrated Microscope for optical image analysis. Outfitted properly the FENIX 300 series of testers excel at testing facilities, Colleges and Universities that require more than just a Rockwell machine.



FENIX 300RS
I-TOUCH™



FENIX 300RS-IMP
IMPRESSIONS™ LT



FENIX 300U
Universal



FENIX 300XL
Extra Tall

Above the current...

It is usually easy to determine how much use a hardness tester gets over its lifetime in a lab. Missing paint, dents and scratches all over the base of the tester, and even rust forms if not corrected in time. Samples fall from the testing area, an occasional bump from a foreign object or just a paint chip from use can make a new machine look aged after short period of time. Our FENIX line is outfitted with an ABS Cover to protect the tester and the samples, including verification blocks, from changing your new tester into the not so new anymore tester. Simply forward focused thinking from an Advanced hardness testing manufacturer.

I-TOUCH™ INTERFACE

Easy to learn, easy to use...

The I-TOUCH™ software on the FENIX 300 series provides clever multi-function on an industrial touchscreen for machine operation such as testing, set-up, storing and uploading of test programs, statistic control and more, making tester operation as easy as it can be.

Data export, single or batch readings, with a single press on a button, or just fully automatic over an USB connection to a PC and imported or evaluated in EXCEL.

Further advanced features include extended statistics, shape correction for convex, concave or ball shaped specimens, hardness conversion to Rockwell, Brinell or Tensile strength according to ASTM E140 and ISO 18625 with different material tables.



MEASUREMENT OVERVIEW



OUT OF SET LIMITS

IMPRESSIONS™ LT INTERFACE

Advanced workflow control...

IMPRESSIONS™ LT installed on the integrated Windows 10 controller provides a modern graphical user interface on the 300RS-IMP. Common sense and simplicity, but yet, includes the most advanced functions found in hardness testing. With only a minimum of operator skills required, IMPRESSIONS™ leads you through the set up process, in just seconds, not even minutes. Standard features, complex tasks and advanced workflow at your fingertips.

Just some of the features :

Scale setting, Test methods setting, Limits, Conversion to other hardness scales, Graphics, File saving, Test program saving, Zoom function, Full screen, etc.

All standardized hardness testing methods have been programmed in the software and can be selected at any time.

INDENT ZOOM MAGNIFICATION

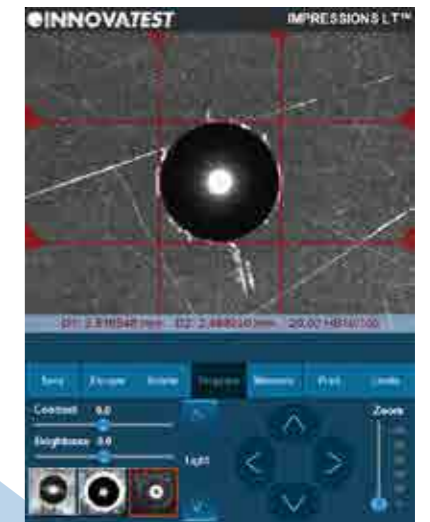

GIPE: GRAPHIC INDENT PROCESS EVALUATION

INNOVATIVE SOFTWARE FUNCTIONS



VARIOUS POSSIBILITIES

The FENIX 300 Series is a workhorse in the range of Rockwell hardness testers. With a throat depth of 150mm and maximum workpiece height of 470mm (XL model), it offers the user a generous workspace. It is designed for 24/7 use and conducts testing at a high speed.

BIOS BRINELL INDENT OPTICAL SCANNER

The FENIX 300RS-IMP can be upgraded with a BIOS system that automatically scans and measures Brinell indents. Both BIOS models 1 & 2 have a high quality optical system with a built-in ring light to assure fast and accurate Brinell measurements.





SUPPORT YOUR BEST TESTING RESULTS

With our rigid designed Bench stands

- Rock solid bench stands
- 100% retractable drawer, bearing guidance, max 100kg load. Rubber anti slip bottom
- Lockable cabinet, 300mm high
- Adjustable feet, (+/- 50mm height adjustable to reach ergonomic working position)
- Made of corrosion resistant zinc plated steel with RAL powder coating
- Carrying capacity of 400kg
- Top surface made of 50mm Plywood with 1.5mm chemical resistant plastic plating, edges made of shock resistant 3mm ABS side liner
- Industrial quality, for workshop or laboratory

Designed for hardness testing instruments, painted in INNOVATEST® RAL colors matching our testers.



UN-STAND/960 71 x 75 x 80 cm

ACCESSORIES FENIX RANGE

Schematic overview of the configuration options, standard and optional accessories

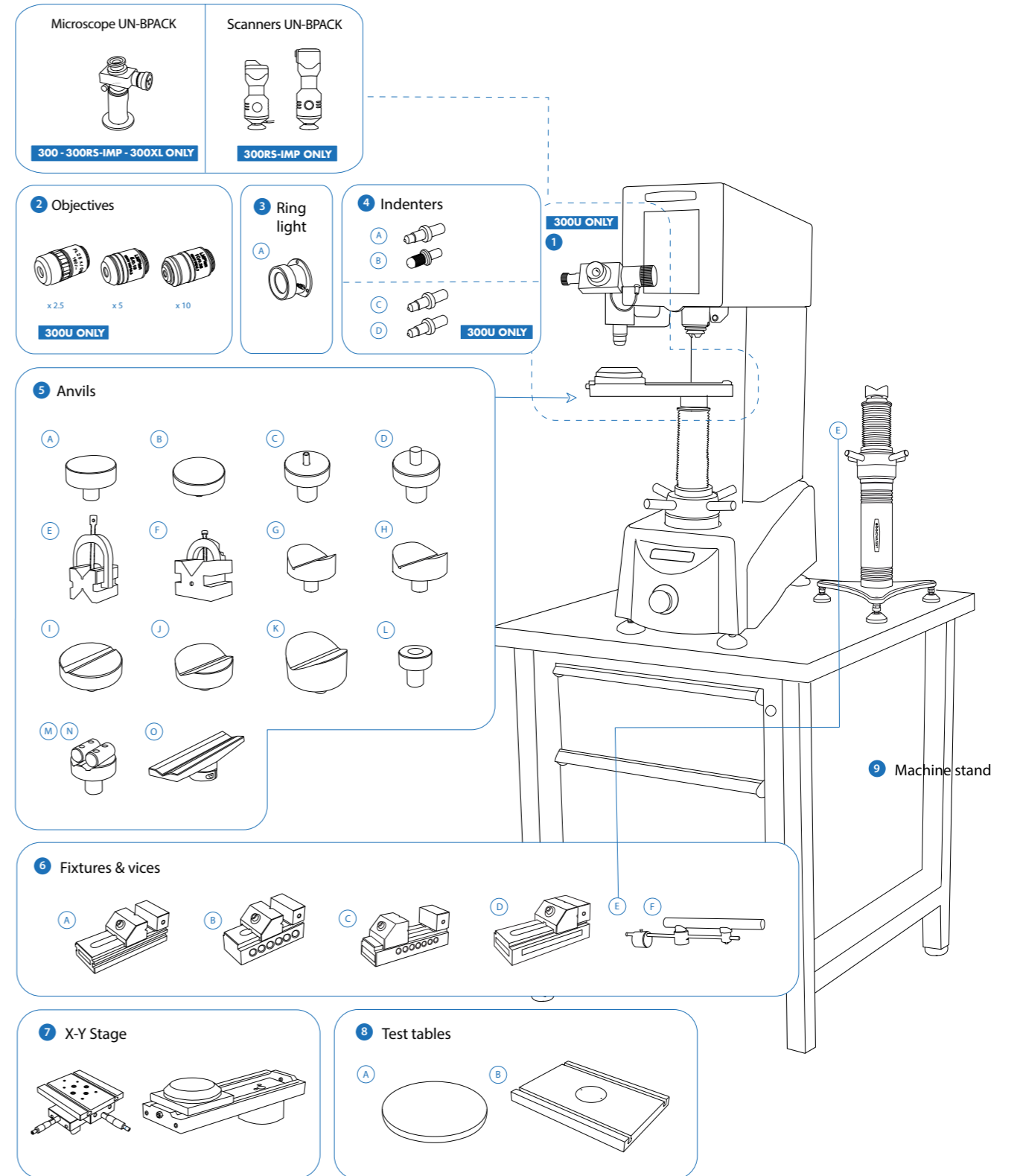

Not all accessories are displayed on this page. Full details can be found on the Order details page.

ORDER DETAILS

FENIX SERIES



| | | |
|--|-----------------|--|
| Fully automatic, load cell, closed loop, Rockwell hardness tester 1kgf - 250kgf | FENIX 300RS | |
| Fully automatic, load cell, closed loop, Rockwell hardness tester 1kgf - 250kgf | FENIX 300RS-IMP | |
| Fully automatic, load cell, closed loop, Rockwell hardness tester 1kgf - 250kgf | FENIX 300XL | |
| Fully automatic, load cell, closed loop, Universal hardness tester 1kgf - 250kgf | FENIX 300U | |
| Plug & Play prepared, calibration, sea & airworthy packing in "non coniferous wood" material (for 300RS, 300RS-IMP & 300U) | P&PSEAPACK190 | |
| Plug & Play prepared, calibration, sea & airworthy packing in "non coniferous wood" material (for 300XL) | P&PSEAPACK200 | |

ACCESSORIES

| | | | | | | | | |
|---|---|---|--|---|---------|-----------------|------------------|--|
| 1 | Eyepiece | Electronic digital eyepiece with 15x magnification (for 300U) | AS-EYEPIECE/03 | STANDARD | | | | |
| 2 | Objectives | Objective 2.5x (for 300U) | ASSV700-OBJ2.5X | STANDARD | | | | |
| | | Objective 5x (for 300U) | ASS9000-10-02 | STANDARD | | | | |
| | | Objective 10x (for 300U) | ASS9000-10-03 | STANDARD | | | | |
| 3 | Ringlight | LED ring light for enhanced Brinell viewing | ASV700-10 | | | | | |
| 4 | Indenters | A | Rockwell C Diamond Indenter. Ø6.35mm. ISO & ASTM certified | IN/6005 | | | | |
| | | | Rockwell Ball Indenter 1/16". Includes 1 carbide ball. Ø6.35mm. ISO & ASTM certified | IN/7506 | | | | |
| | | | Rockwell Ball Indenter 1/8". Includes 1 carbide ball. Ø6.35mm. ISO & ASTM certified | IN/7606 | | | | |
| | | | Rockwell Ball Indenter 1/4". Includes 1 carbide ball. Ø6.35mm. ISO & ASTM certified | IN/7706 | | | | |
| | | | Rockwell Ball Indenter 1/2". Includes 1 carbide ball. Ø6.35mm. ISO & ASTM certified | IN/7806 | | | | |
| | | B | Brinell Indenter 1mm. Includes 1 carbide ball. Ø6.35mm. ISO & ASTM certified | IN/7000 | | | | |
| | | | Brinell Indenter 2.5mm. Includes 1 carbide ball. Ø6.35mm. ISO & ASTM certified | IN/7005 | | | | |
| | | | Brinell Indenter 5mm. Includes 1 carbide ball. Ø6.35mm. ISO & ASTM certified | IN/7010 | | | | |
| | | | Brinell Indenter 10mm. Includes 1 carbide ball. Ø6.35mm. ISO & ASTM certified | IN/7015 | | | | |
| | | | C | Macro Vickers Indenter Ø6.35mm, ISO & ASTM certified (for 300U) | IN/8010 | | | |
| | | D | Macro Knoop Indenter Ø6.35mm, ISO & ASTM certified (for 300U) | IN/8220 | | | | |
| | | | 5 | Anvils | A | Flat anvil 60mm | AS3000-19-04 | |
| | | | | | B | Flat anvil 80mm | UN-TESTTABLE/002 | |
| | | | | | C | Spot anvil 5mm | UN-ANVIL/010 | |
| | | | | | D | Spot anvil 10mm | UN-ANVIL/011 | |
| E | V block with bracket 40x40x50mm (LxBxH) | UN-VBLOCK404050 | | | | | | |
| F | Steel, cross type, (X) V-block 60x120x100mm 8-90mm pair | F | Steel, cross type, (X) V-block 60x120x100mm 8-90mm pair | UN-CROSSBLOCK01 | | | | |
| | | G | V-anvil ø40mm 6-60mm | UN-ANVIL/005 | | | | |
| | | H | V-anvil ø63mm 10-100mm | UN-ANVIL/006 | | | | |
| | | I | V-Anvil ø80mm 3.3-20mm | UN-ANVIL/040 | | | | |
| | | J | V-Anvil ø80mm 15-80mm | UN-ANVIL/045 | | | | |
| | | K | V-Anvil ø80mm 23-40mm | UN-ANVIL/050 | | | | |
| | | L | Anvil for round specimen dia. 6-25,4mm | UN-ANVIL/200 | | | | |
| | | M | Cylindrical V anvil 6-80mm | UN-CVANVIL680 | | | | |
| | | N | Cylindrical V anvil 50-200mm | UN-CVANVIL50200 | | | | |
| | | O | Extra long V-Anvil (Ø10 - Ø100) (for 300RS, 300RS-IMP & 300XL) | CM-08-0186 | | | | |

| | | | | |
|---|-------------------------------------|--|---|------------------|
| | | Test table 100x100mm, V groove 20mm wide, 10mm deep | UN-TESTTABLE/040 | |
| 6 | Fixtures and Vices | A | Polished precision vice with lock down system, jaw width 25mm, opens 20mm | UN-VICE/210 |
| | | B | Polished precision vice with lock down system, jaw width 36mm, opens 42mm | UN-VICE/215 |
| | | C | Polished precision vice with lock down system, jaw width 48mm, opens 75mm | UN-VICE/220 |
| | | D | Polished precision vice with lock down system, jaw width 75mm, opens 100mm | UN-VICE/230 |
| | | E | Jack Rest (for 300RS, 300RS-IMP & 300XL) | SA-08-0010 |
| | | F | Adjustable Vari rest (for 300RS, 300RS-IMP & 300XL) | SA-08-0013 |
| 7 | X-Y Stage | Manual X-Y stage with analogue metric micrometers, 180x160mm Displacement: 25x25mm, scale 0.01mm, max load 300kg | UN-TESTTABLE/030 | |
| | | Sliding platform of the sliding unit (for 300U) | ASV700-22-01B | STANDARD |
| | Clamping, Locking & Fixing Adapters | Manual X-Y stage connecting plate | UN-TESTTABLE/ 030FAPL | |
| | | Lock flange | UN-XYZ BUSH42 | |
| | | X-Y slide adaptor (for 300U) | ASV700-22-02 | STANDARD |
| 8 | Test Tables | A | Testing table Ø200mm (61-65HRC) requires lock flange (for 300RS, 300RS-IMP & 300XL) | CM-08-0194 |
| | | | Testing table flat ø180mm, screwfix | ASV700-00-20 |
| | | | Testing table flat ø235mm, screwfix | UN-TESTTABLE/014 |
| | | B | Large flat surface testing table 350x250mm, thickness 30mm with 2 T-slots, for large components | UN-TESTTABLE/015 |
| | | | Lock flange | ASV700-21-01 |
| 9 | Machine stand | Cabinet test table with drawer for hardness testers 71x75x80cm | UN-STAND/960 | |
| | | Seaworthy packing box for 950/960 | PACK/100 | |
| | ISO / ASTM Verification | BRINELL direct and indirect verification/calibration & certification in compliance with ISO & ASTM, NADCAP. Includes direct force and indirect verification report (block readings), GR & R report, flat fee for selected common scales, per scale. | CALCEFRDW/1B | |
| | | ROCKWELL direct and indirect verification/calibration & certification in compliance with ISO & ASTM, NADCAP. Includes direct force and indirect verification report (block readings), GR & R report, flat fee for selected common scales, per scale. | CALCEFRDW/1R | |
| | | VICKERS direct and indirect verification/calibration & certification in compliance with ISO & ASTM, NADCAP. Includes direct force and indirect verification report (block readings), GR & R report, flat fee for selected common scales, per scale (for 300U). | CALCEFRDW/1V | |
| | Covers | KNOOP direct and indirect verification/calibration & certification in compliance with ISO & ASTM, NADCAP. Includes direct force and indirect verification report (block readings), GR & R report, flat fee for selected common scales, per scale (for 300U). | CALCEFRDW/1K | |
| | | Machine cover 600x700x1100mm (for 300XL) | UN-COVER5 | |
| | | Machine cover 350x550x770mm (for 300RS, 300RS-IMP & 300U) | UN-COVER1 | |

SOFTWARE

| | | | | |
|--|-------------------|---|--------------|----------|
| | Connectivity Plus | Interface cable for PC | UN-CABLE/910 | |
| | | Utility software; Import test results in MS applications like Excel | UN-SW/905 | |
| | | Blue Tooth connectivity (for 300RS-IMP) | UN-BTADAPT | |
| | Upgrades | Wireless system Keyboard & wireless mouse (for 300RS-IMP) | UN-SKBSET | STANDARD |
| | | Upgrade Rockwell tester RS to RSB, Brinell scales, analogue microscope 40x | UN-BPACK01 | |
| | | Upgrade Rockwell tester RS to RSB, Brinell scales, BIOS 1 system, IMPRESSIONS™ Lite | UN-BPACK06 | |
| | | Upgrade Rockwell tester RS to RSB, Brinell scales, BIOS 2 system, IMPRESSIONS™ Lite | UN-BPACK07 | |

ACCESSORIES

MICROSCOPES

UN-BPACK



AS3001-MICRO/01
AS3001-MICRO/02

SCANNERS

UN-BPACK



SA-12-0001 SA-12-0002

EYE PIECE



AS-EYEPIECE/03

OBJECTIVES



RINGLIGHT



ASV700-10

INDENTERS



ANVILS



FIXTURES & VICES



X-Y STAGE



TEST TABLES



MACHINE STAND



COVERS



SPECIFICATIONS



| TEST FORCE | | | FENIX 300RS | FENIX 300RS-IMP | FENIX 300U | FENIX 300XL |
|---|---------------------------------|---|-----------------------|-----------------------|-----------------------|------------------------|
|  | TEST FORCES | 1kgf - 250kgf | + | + | + | + |
| | FORCE APPLICATION | Load cell, closed loop, force feedback system | + | + | + | + |
| HARDNESS SCALES | | | | | | |
|  | VICKERS | HV1 HV2.5 HV3 HV4 HV5 HV10 HV20 HV25 HV30 HV40 HV50 HV100 HV120 | - | - | + | - |
| | KNOOP | HK1 HK2.5 HK3 HK4 HK5 | - | - | + | - |
| | ROCKWELL | Regular Rockwell scales; Pre Load 10kgf, Main Load 60kgf 100kgf 150kgf A B C D E F G H K L M P R S V Superficial Rockwell scales; Pre Load 3kgf, Main Load 15kgf 30kgf 45kgf 15N 30N 45N 15T 30T 45T 15W 30W 45W 15X 30X 45X 15Y 30Y 45Y | + | + | + | + |
| | BRINELL | HBW1/2.5 HBW1/5 HBW1/10 HBW1/30 HBW2.5/6.25 HBW2.5/7.8125 HBW2.5/15.625 HBW2.5/31.25 HBW2.5/62.5 HBW2.5/187.5 HBW5/25 HBW5/31.25 HBW5/62.5 HBW5/125 HBW5/250 HBW10/100 HBW10/125 HBW10/250 | Optional | Optional | + | Optional |
| | PLASTIC ISO 2039-1/2 | 49 N, 132 N, 358 N, 961 N | + | + | + | + |
| | HVD (HVT) | HV1 HV5 HV10 HV20 HV25 HV30 HV40 HV50 HV60 HV100 HV120 HV125 HV150 | + | + | + | + |
| | HBD (HBT) | HB1/5 HB1/10 HB1/30 HB2.5/6.25 HB2.5/7.8125 HB2.5/15.625 HB2.5/31.25 HB2.5/62.5 HB2.5/187.5 HB5/25 HB5/31.25 HB5/62.5 HB5/125 HB5/250 HB10/100 HB10/125 HB10/250 | + | + | + | + |
| | CARBON | HR 2.5/7 HR 5/7 HR 5/15 HR 5/20 HR 5/40 HR 5/60 HR 5/100 HR 5/150 HR 10/20 HR 10/40 HR 10/60 HR10/100 HR 10/150 | + | + | + | + |
| SYSTEM | | | | | | |
|  | I-TOUCH™ | Graphic User Interface, Full color touchscreen, USB-2 | + | - | + | + |
| | IMPRESSIONS™ LT | Integrated system controller, Windows 10, full color touchscreen, LAN, W-LAN, USB-3 | - | + | - | - |
| GENERAL | | | | | | |
|  | MACHINE DIMENSIONS | | 270mm x 580mm x 770mm | 270mm x 580mm x 770mm | 325mm x 640mm x 770mm | 440mm x 580mm x 1000mm |
| | MACHINE WEIGHT | | 115kg | 115kg | 115kg | 140kg |
| | TEST FORCE TOLERANCE | < 0.5% | + | + | + | + |
| | DWELL TIME SETTINGS | Default 1 second, user defined. Up to 99 seconds | + | + | + | + |
| | OPERATING TEMPERATURE | 10°C to 35°C | + | + | + | + |
| | POWER CONSUMPTION | <100W | + | + | + | + |
| | HUMIDITY | 10% to 90%, non-condensing | + | + | + | + |

TECHNICAL DRAWINGS

All dimensions in these drawings are in mm, approximate. Working heights and or workpiece accommodation varies depending on the stages and stage accessories used.

Please contact our sales department for more details.

FENIX 300

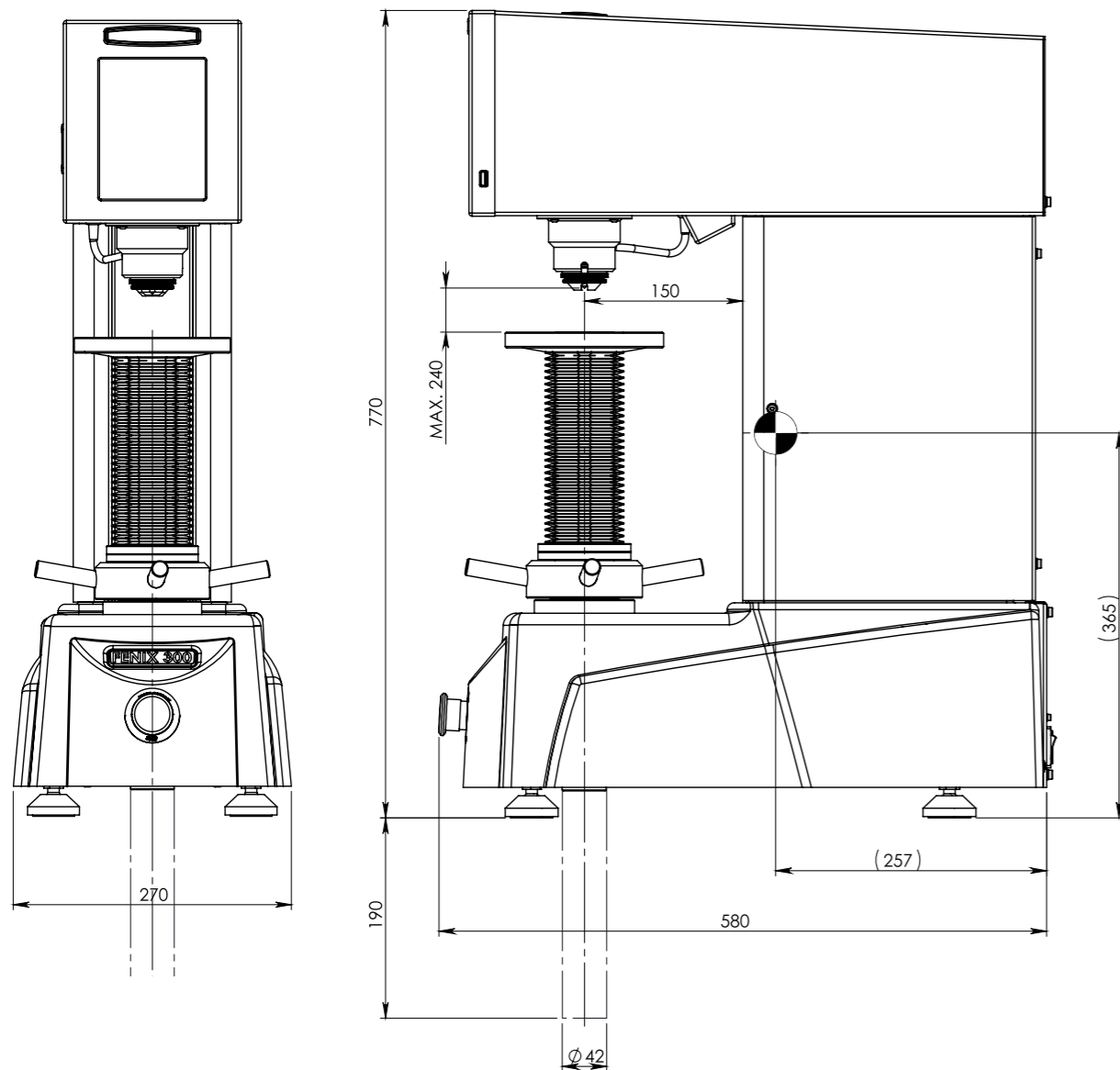

FENIX 300XL

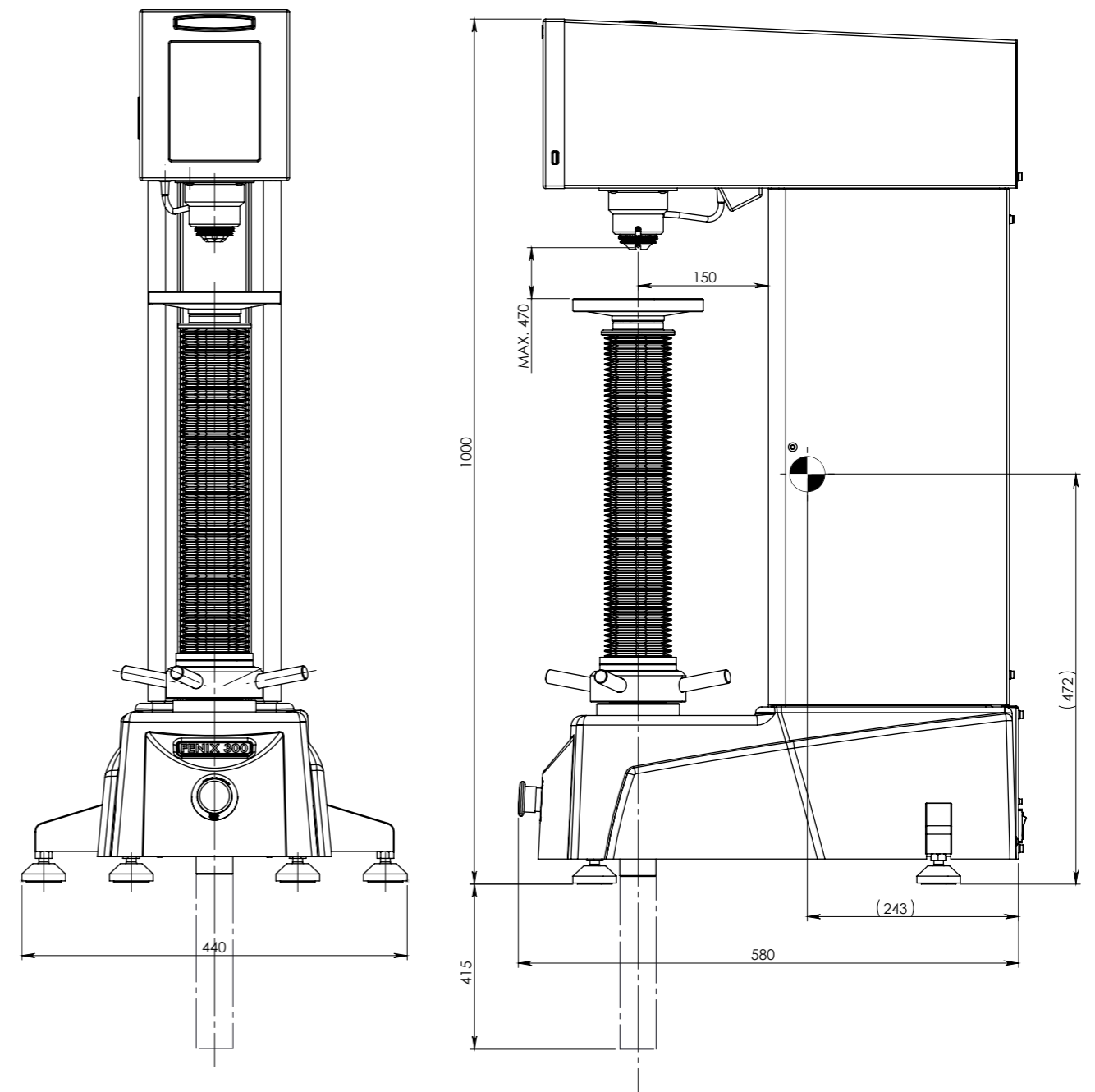

OTHER MODELS IN THE ROCKWELL RANGE



FENIX 200AR

Load applied from a dead weight force actuator Rockwell / Brinell hardness tester.

See brochure B18F200/XX



FENIX 200ACL

Load Cell, closed loop, force feedback, test force application system Rockwell / Brinell hardness tester.

See brochure B18F200/XX



FENIX 200DCL

Load Cell, closed loop, force feedback, test force application system Rockwell / Brinell hardness tester.

See brochure B18F200DCL/XX



NEMESIS 6100

Load Cell, Closed loop Fully automatic Rockwell/ Superficial Rockwell (Brinell) hardness tester with descending test head & fixed workpiece position. full color touchscreen operation.

See brochure B18N6100/XX



NEMESIS 6200

Load Cell, Closed loop Fully automatic Rockwell/ Superficial Rockwell (Brinell) hardness tester with descending test head & fixed workpiece position, integrated PC, Windows 10, Wifi, full color 15" industrial capacitive touchscreen.

Includes CNC motorized X-Y stage, overview camera and advanced software (IMPRESSIONS™) for automatic pattern testing and fixture recognition.

See brochure B18N6200/XX



VERZUS 710

Load Cell, closed loop Rockwell/Superficial Rockwell/ Brinell hardness tester, with direct depth measuring system, integrated PC, Windows 10, wifi, full color touchscreen.

See brochure B18V710/XX



VERZUS 720

Load Cell, closed loop Rockwell/Superficial Rockwell/ Brinell hardness tester, with direct depth measuring system, integrated PC, Windows 10, wifi, full color touchscreen.

See brochure B18V720/XX



NEMESIS 9100RS

Load Cell, closed loop Rockwell/Superficial Rockwell/ Brinell hardness tester, with integrated PC, Windows 10, WiFi etc. full color touchscreen.

See brochure B18N9100/XX



NEMESIS 9600RSB

Floor type, Load Cell, closed loop. Brinell, Rockwell, Superficial Rockwell Hardness tester With motorized Z-axis & BIOS Brinell Indent Optical Scanner

See brochure B19N9600/XX

www.innovatest-europe.com

Changes in products and/or product specifications can emerge due to new technologies and continuous development.

We reserve the right to change or modify specifications of the products without prior notice. We recommend you to contact our sales office for up-to-date information.

Brochure B20F300/06/EN

© All rights reserved, 2020

Distributor :

CORPORATE HEAD OFFICE

INNOVATEST Europe BV

Manufacturing, Distribution & Service

Borgharenweg 140
6222 AA MAASTRICHT
The Netherlands

Phone: +31 43 3520060

Fax: +31 43 3631168

info@innovatest-europe.com

www.innovatest-europe.com

INNOVATEST Deutschland GmbH Sales & Service

Phone: +49 245 670 59 500
info@innovatest-deutschland.com
www.innovatest-deutschland.com

INNOVATEST France SARL Sales & Service

Phone: +33 1848 88038
info@innovatest-france.com
www.innovatest-france.com

INNOVATEST USA Company Sales & Service

Phone: +1 267 317 4300
info@innovatest-usa.com
www.innovatest-usa.com

INNOVATEST Japan K.K Sales & Service

Phone: +81 3 6667 0554
info@innovatest-japan.com
www.innovatest-japan.com

INNOVATEST UK Ltd. Sales & Service

Phone: +44 121 274 0105
info@innovatest-uk.com
www.innovatest-uk.com

INNOVATEST Polska sp. z.o.o Sales & Service

Phone: +48 697 099 826
info@innovatest-polska.pl
www.innovatest-polska.pl

INNOVATEST Shanghai Co., Ltd. Sales & Service

Phone: +86 21 60906200
info@innovatest-shanghai.com
www.innovatest-shanghai.com

INNOVATEST South East Asia Sales & Service

Phone: +65 6451 1123
info@innovatest-singapore.com
www.innovatest-singapore.com